

Psychro - Transmitter

Instruction for use 1.1130.20.000 / 1.1130.22.000



Table of Contents

1. General Information
 2. Models
 3. Set-up of the Instrument
 4. Mode of Operation
 5. Technical Data
 6. Mounting
 7. Maintenance
 8. Connection Diagram
 9. Dimension
- enclosed : Table of Psychrometer

1. General Information

The instrument is designed to determine the exact humidity values of the atmosphere surrounding the instrument. Both measuring values, wet bulb temperature and dry temperature, are available as electrical

2. Models

Description	Order – No.	Operating voltage for Ventilator
Psychro- Transmitter	1.1130.20.000	12 V AC, 6 W 24 V AC, 11 W 24 V DC, 8 W
Psychro- Transmitter	1.1130.22.000	12 V DC, 4W

3. Set-up of the Instrument

The sensors. Complete have been screwed at an angle to the holder. This angle is such that the resistance thermometers (PT100) protrude from the opposite side. Each PT 100 is enclosed in a radiation protection device and screwed into the holder. One of the sensors, complete, has bore hole facing the water container. The sock, one end of which is pulled over the wet-bulb thermometer, the bore hole. The water container is screwed into the holder from below. The two resistance thermometers are ventilated by means of a bore hole towards the top of the suction tube. The suction tube is screwed to the ventilator. The ventilator is a radial fan with a air outlet located on the back of the measuring sensor below the ventilator.

A bracket for wall mounting has been provided.

The ventilator and the sensor, complete can be connected to the power supply by means of plug connections.

4. Mode of Operation

Humidity values are determined through temperature measurements. 2 temperatures are required for this:

1. the temperature of the air
2. the evaporation temperature of water

Resistance thermometers (Pt 100) with standardized characteristics for interchange-ability have been employed. The resistance values of these sensors change with changing temperature. This value is a measurement of temperature. The ventilator sucks the air past the resistance thermometers. The radiation protection devices protect the PT 100 from light and guarantee that the actual air temperatures is measured.

One PT 100 is covered by a sock which is partially submerged in the water of the water container. Due to the capillary effect of the material, the water from the water container creeps up the sock and wets the resistance thermometer. The air flow draws off evaporation heat from the wet sock and this results in a wet-bulb temperature in accordance with the temperature and the humidity which is lower than the normal humidity. Out of the difference between these two temperatures, it is possible to calculate the dew point or the relative humidity of the surrounding atmosphere by means of the Sprung formula or the read these values in the table.

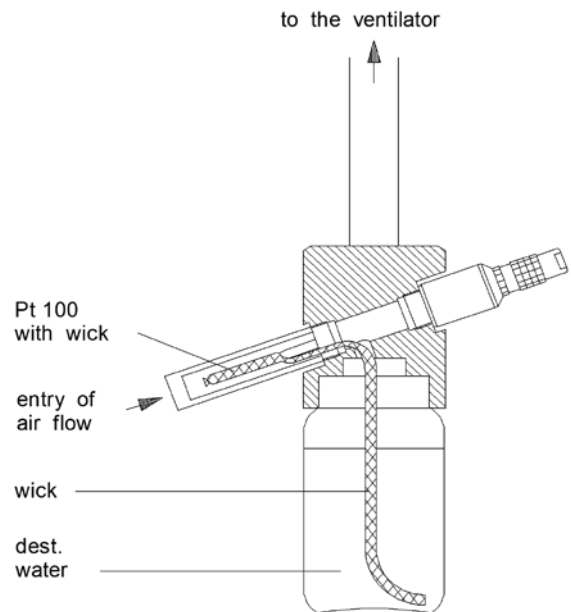

5. Technical Data

Measuring range	: 0...60°C
Sensors	: 2 Pt 100 DIN 43760
Accuracy	: $\pm 0,1^\circ\text{K}$; 1/3 class B
Time constant	: 17 s (90 %)
Ventilation	: 4...6 m/s
Water container	: 250 ml
Fluid	: distilled water
Operating voltage	: see connection diagram (chapter 8)
Cables	: sensor: LiYCY 4x0,25 mm ² ventilator: LiYY 3x0,5 mm ²
Mounting	: with bracket
Dimension	: Ø160 mm, 465 mm high
Weight	: 3,7 kg

Table: Resistant values in Ohm from 1 to 1°C for Pt 100

°C	0	1	2	3	4	5	6	7	8	9
0	100,00	100,39	100,78	101,17	101,56	101,95	102,34	102,73	103,12	103,51
10	103,90	104,29	104,68	105,07	105,46	105,85	106,24	106,63	107,02	107,40
20	107,79	108,18	108,57	108,96	109,35	109,73	110,12	110,51	110,90	111,28
30	111,67	112,06	112,45	112,83	113,22	113,61	113,99	114,38	114,77	115,15
40	115,54	115,93	116,31	116,70	117,08	117,47	117,85	118,24	118,62	119,01
50	119,4	119,78	121,16	120,55	120,93	121,325	121,70	122,09	122,47	122,86
60	123,24	123,62	124,01	124,39	124,77	125,16	125,54	125,92	126,31	126,69

6. Mounting

For trouble free measurement and protection against damage of ventilator and resistant thermometer, the transmitter must be mounted vibration free. The operating of the Pt 100 protection shield must show to the north direction, to avoid radiation influence.

The distance of the Psycho-Transmitter to any reflection surface (wall etc) should be a minimum of 30 cm. Standard supplied hanger is prepared for mounting by 4 screws (8 mm Ø).

Connect the instruments according to the circuit diagram. Please make sure that you use connecting cable (see technical data) suitable for a water-proof plug.

Fill the water container before switching on the voltage. To do so, unscrew it from the instrument. Then fill it with distilled water. The instrument is ready for use as soon as the container has been replaced.

7. Maintenance

Due to the constant ventilation of the sensor, dust tends to settle on the radiation device and on the moistening sock. If these sections become too dirty, then accurate measurements are no longer guaranteed. The sock must be changed punctually. You can change the sock by observing the following procedure:

- Remove the plug and the radiation protection device. Pull carefully on the dirty moistening sock and unscrew the sensor. The radiation protection tubes can be washed out in distilled water or methylated spirits. For the sake of measuring accuracy are to be kept clean and free of dust. The measuring sensor is fragile, and must, therefore, be cleaned very carefully. In case of breaking the sensor can be reordered under the description „measuring sensor 2.1266.10.001“.
- Unscrew the water container and pull the sock upwards out of the holder.
- Measure off a length of 220 mm on the new sock, tie it off sew it with thread then cut off the rest and pull the new sock through the holder as illustrated.
- Punch a hole in the moistening sock 40 mm behind the cut off point with the aid of the enclosed pin. (press the pin in as far as the marking).
- While screwing the sensor back into place, draw the pre-formed sock carefully over the Pt 100. It must lie snugly against the sensor on all sides.
- Clean the radiation protection tube and re-screw it, put the plug back on, fill the water container with distilled water and screw is back into the holder.

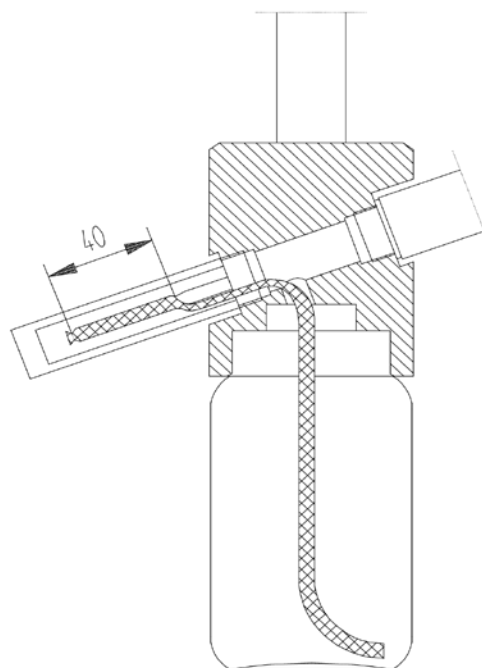

When switching on again the motor can lock and the winding can burn out. For this application it is recommendable to install an overload-protection fuse.

8. Connection Diagramm

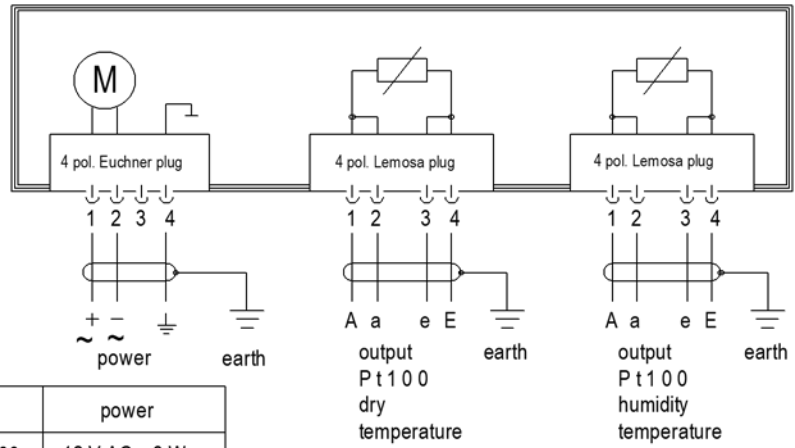

Order-No.	power
1. 1130. 20. 000	12 V AC , 6 W 24 V AC ,11 W 24 V DC , 8 W
1. 1130. 22. 000	12 V DC , 4 W

9. Dimension

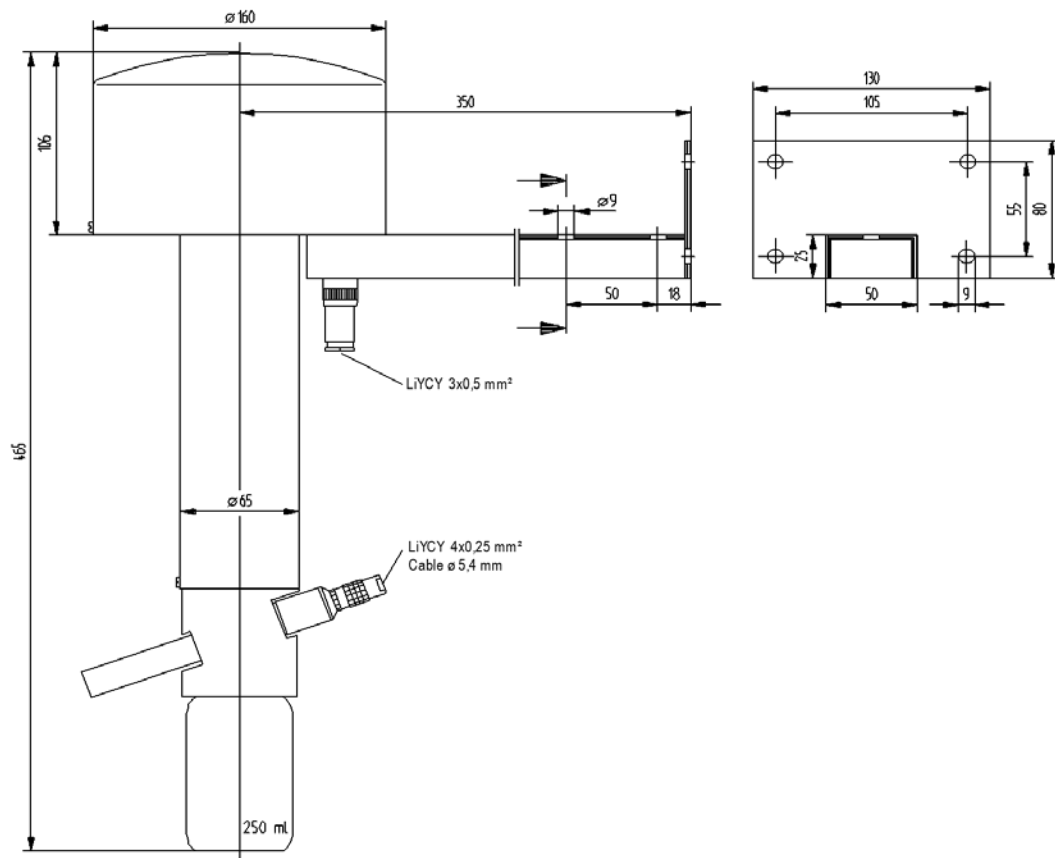

EU-Declaration of Conformity

Document-No.: 000260

Month: 08 Year: 16

Manufacturer: **ADOLF THIES GmbH & Co. KG**

Hauptstr. 76
D-37083 Göttingen
Tel.: (0551) 79001-0
Fax: (0551) 79001-65
email: Info@ThiesClima.com

This declaration of conformity is issued under the sole responsibility of the manufacturer

Description of Product: **Psychro – Transmitter**

Article No. **1.1130.20.000** **1.1130.22.000**

specified technical data in the document: **020974/10/03**

The indicated products correspond to the essential requirement of the following European Directives and Regulations:

2014/30/EU	DIRECTIVE 2014/30/EU OF THE EUROPEAN PARLIAMENT AND OF THE COUNCIL of 26 February 2014 on the harmonisation of the laws of the Member States relating to electromagnetic compatibility
2014/35/EU	DIRECTIVE 2014/35/EU OF THE EUROPEAN PARLIAMENT AND OF THE COUNCIL of 26 February 2014 on the harmonisation of the laws of the Member States relating to the making available on the market of electrical equipment designed for use within certain voltage limits
552/2004/EC	Regulation (EC) No 552/2004 of the European Parliament and the Council of 10 March 2004 on the interoperability of the European Air Traffic Management network (the interoperability Regulation)
2011/65/EU	DIRECTIVE 2011/65/EU OF THE EUROPEAN PARLIAMENT AND OF THE COUNCIL of 8 June 2011 on the restriction of the use of certain hazardous substances in electrical and electronic equipment
2012/19/EU	DIRECTIVE 2012/19/EU OF THE EUROPEAN PARLIAMENT AND OF THE COUNCIL of 4 July 2012 on waste electrical and electronic equipment (WEEE)

The indicated products comply with the regulations of the directives. This is proved by the compliance with the following standards:

EN 61000-6-2	Electromagnetic compatibility Immunity for industrial environment
EN 61000-6-3	Electromagnetic compatibility Emission standard for residential, commercial and light industrial environments
EN 61010-1	Safety requirements for electrical equipment for measurement, control, and laboratory use. Part 1: General requirements
EN 50581	Technical documentation for the assessment of electrical and electronic products with respect to the restriction of hazardous substances



Place: Göttingen

Date: 24.08.2016

Signed for and on behalf of:

Legally binding signature:

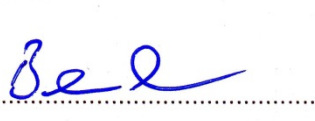
issuer:



Thomas Stadie, General Manager

Joachim Beinhorn, Development Manager

This declaration certifies the compliance with the mentioned directives, however does not include any warranty of characteristics. Please pay attention to the security advises of the provided instructions for use.

Your local distributor:

ekotechnika
měřicí technika pro ekologii

Ing. Milan Kříž - Ekotechnika
Kloboučnická 20, 140 00 Praha 4

 +420 241 414 111

 info@ekotechnika.com

 www.ekotechnika.com



ADOLF THIES GMBH & CO. KG

Hauptstraße 76

Postfach 3536 + 3541

Tel. +49(0)551 79001-0

www.thiesclima.com

37083 Göttingen

37025 Göttingen

Fax +49(0)551 79001-65

info@thiesclima.com



- Änderungen vorbehalten-